

Complete Range of Fire Protection



WHEN FIRE DISOBEYS

LIFEGUARD[®]

FIRE PROTECTION EQUIPMENTS & SYSTEMS

ABOUT US



VISION

To be India's most trusted and innovative fire safety solutions provider.



MISSION

To protect lives, assets, environment and progress with world-class firefighting equipment and State-of-the-art technologies.

PIONEERING ACHIEVEMENTS

• HMS - Hydrated Mica Suspension

Next-generation extinguishing agent developed specifically for Lithium-ion Battery Fires in EVs, Energy Storage Systems, and high-risk facilities.

• Bus Passenger Compartment (Water Mist) & Engine (Foam Based) Fire Detection & Suppression System

(DRDO - Transfer of Technology) A fully automated **detection, alarm, and suppression solution** ensuring passenger safety and preventing catastrophic engine fires.

• Agni - Rodhak

Passive Fire Protection Coating (ISRO - Transfer of Technology) Advanced **fire-proof coating** providing structural resilience and safeguarding assets from extreme fire exposure.



COMMITMENT THAT INSPIRES TRUST

What we say is **COMMITMENT**

What we **DELIVER** is **QUALITY**

What we create is **LIFEGUARD**

OUR LEGACY

- Over **42 years of excellence** in firefighting equipment manufacturing.
- Among the leading **ISI-marked fire protection brands** in India & member of BIS (CED 22.2) Committee
- Trusted by **Defence, infrastructure, transport, and industrial sectors** nationwide.

IFE AWARD



IFE Award: For Indigenous development of HMS (Hydrated Mica Suspension) indigenous development 'Innovative Product of the Year - 2025' for HMS (Hydrated Mica Suspension) to be used on critical fires involving lithium-ion battery specific fires at the event of FIRE INDIA 2025, Mumbai on 25th September, 2025

CII AWARD



CII Award : United Fire Equipments Pvt. Ltd. recognized among the Top Innovative Companies of India under the CII Industrial Innovation Awards 2025 on 16th December 2025, at the CII Global Summit on Technology, R&D & Intellectual Property, held at Hotel Le Meridien, New Delhi.



AWARDS



IS-15683

 CML-0008633079

LIFE GUARD[®]
 FIRE PROTECTION EQUIPMENTS & SYSTEMS

HMS Fire Extinguisher
 Fire tests carried out as per NTA-8133

1ST TIME IN INDIA
 Non-Toxic Eco Friendly

LiON-Ex[®]
 FOR LITHIUM BATTERY FIRES

Application Areas

- 01 Energy Storage | 02 Aviation
- 03 Domestic | 04 Marine
- 05 Industrial | 06 Logistics
- 07 Surface Transport

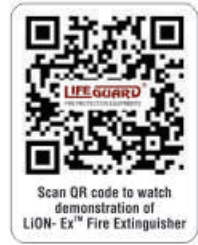

MODEL	LG-181	LG-182	LG-184	LG-186	LG-189
Capacity (Ltr.)	1	2	4	6	9
Anti-Corrosive Inhibitor	Pure Polyester Powder Coating	Pure Polyester Powder Coating	Pure Polyester Powder Coating	Pure Polyester Powder Coating	Pure Polyester Powder Coating
Type of Extinguisher	Stored Pressure	Stored Pressure	Stored Pressure	Stored Pressure	Stored Pressure
Type of Extinguishing Media	Hydrated Mica Suspension	Hydrated Mica Suspension	Hydrated Mica Suspension	Hydrated Mica Suspension	Hydrated Mica Suspension
Expellant	Pressurized Nitrogen gas	Pressurized with Nitrogen gas	Pressurized with Nitrogen gas	Pressurized with Nitrogen gas	Pressurized with Nitrogen gas
Confirming IS Code Specification	N.A.	15683	15683	15683	15683
Min. Effective Discharge (%)	95	95	95	95	95
Lancing Distance (mtrs.)	More than 2 mtr.	More than 2 mtr.	More than 2 mtr.	More than 2 mtr.	More than 2 mtr.
Hydraulic Test Pressure (kgf/cm ²)	35	35	35	35	35
Operating Position	Upright	Upright	Upright	Upright	Upright
Working Pressure (kgf/cm ²)	15	15	15	15	15
Operating Temperature Range (°C)	(+5°C to +)60°C	(+5°C to +)60°C	(+5°C to +)60°C	(+5°C to +)60°C	(+5°C to +)60°C
Operating Valve	Squeeze Grip Type with Discharge hose & Special Nozzle	Squeeze Grip Type with Discharge hose & Special Nozzle	Squeeze Grip Type with Discharge hose & Special Nozzle	Squeeze Grip Type with Discharge hose & Special Nozzle	Squeeze Grip Type with Discharge hose & Special Nozzle

*Note: HMS can be used with Wheeled Fire Extinguisher for larger applications and Fixed Suppression System for Energy Storage or High Risk Areas



Powder Portable Fire Extinguisher
 (Stored Pressure/Gas Cartridge Type)

IS-15683

 CML-0008633079

Technical Specification

MODEL	LG-121	LG-122	LG-124/224	LG-126/226	LG-129/229
Capacity (Kg)	1	2	4	6	9
Anti-Corrosive Inhibitor	Epoxy Polyester Powder Coating	Epoxy Polyester Powder Coating	Epoxy Polyester Powder Coating	Epoxy Polyester Powder Coating	Epoxy Polyester Powder Coating
Confirming IS Code	15683	15683	15683	15683	15683
Type of Extinguisher	Constant Pressure	Constant Pressure	Constant Pressure/Gas Cartridge	Constant Pressure/Gas Cartridge	Constant Pressure/Gas Cartridge
Type of Extinguishing Media	Dry Powder IS 14609/IS 4308	Dry Powder IS 14609/IS 4308	Dry Powder IS 14609/IS 4308	Dry Powder IS 14609/IS 4308	Dry Powder IS 14609/IS 4308
Expellant	Pressurized Nitrogen gas	Pressurized Nitrogen gas	Pressurized Nitrogen gas/ 90gm/120gm Gas Cartridge	Pressurized Nitrogen gas/ 120gm Gas Cartridge	Pressurized Nitrogen gas/ 200gm Gas Cartridge
Minimum Effective Discharge (%)	85	85	85	85	85
Lancing Distance (mtrs.)	More than 2 mtr.	More than 2 mtr.	More than 2 mtr.	More than 2 mtr.	More than 2 mtr.
Effective Discharge Time (Sec.)	8 seconds (Minimum)	13 seconds (Minimum)	13 seconds (Minimum)	13 seconds (Minimum)	13 seconds (Minimum)
Hydraulic Test Pressure (kgf/cm ²)	35	35	35	35	35
Operating Position	Upright	Upright	Upright	Upright	Upright
Charged Pressure (kgf/cm ²)	15	15	15	15	15
Operating Temperature Range(°C)	(-30 to +)60	(-30 to +)60	(-30 to +)60	(-30 to +)60	(-30 to +)60
Operating Valve	Squeeze Grip Type with Nozzle	Squeeze Grip Type with Nozzle	Squeeze Grip Type with Discharge hose and Nozzle	Squeeze Grip Type with Discharge hose and Nozzle	Squeeze Grip Type with Discharge hose and Nozzle
Fire Rating	≤ 1A, 21B, C	≤ 1A, 34B, C	≤ 2A, 89B, C	≤ 3A, 144B, C	≤ 4A, 233B, C

- Also Available in Stainless Steel Body
- Also available in MAP 90% & UL Listed Powder



Water/ Foam / Water Mist Portable Fire Extinguisher (Stored Pressure / Gas Cartridge Type)

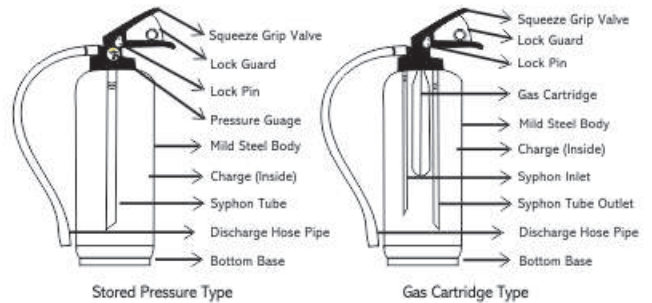

Technical Specification

MODEL	WATER	FOAM	WATER MIST
	LG-109/209	LG-119/219	LG-164 / LG-166 / LG-169
Capacity (Ltr.)	9	9	4 / 6 / 9
Anti-Corrosive Inhibitor	Epoxy Polyester Powder Coating	Epoxy Polyester Powder Coating	Epoxy Polyester Powder Coating
Confirming IS Code	15683	15683	15683
Type of Extinguisher	Constant Pressure/Gas Cartridge	Constant Pressure/Gas Cartridge	Constant Pressure
Type of Extinguishing Media	Potable Water	Water & AFFF IS 4989	Potable Water with Additives
Expellant	Pressurized with N ₂ gas/ 90gm/120gm Gas Cartridge	Pressurized with N ₂ gas/ 90gm/120gm Gas Cartridge	Pressurized with N ₂ gas
Minimum Effective Discharge (%)	95	95	95
Lancing Distance (mtrs.)	More than 2 mtr.	More than 2 mtr.	More than 2 mtr.
Discharge Time (Sec.)	13 seconds (Minimum)	13 seconds (Minimum)	13 seconds (Minimum)
Hydraulic Test Pressure (kgf/cm ²)	35	35	35
Operating Position	Upright	Upright	Upright
Charged Pressure (kgf/cm ²)	15	15	15
Operating Temperature Range(°C)	(+5 to +)60	(+5 to +)60	(+5°C to (+)60°C
Operating Valve	Squeeze Grip Type with Discharge hose and Nozzle	Squeeze Grip Type with Discharge hose and Nozzle	Squeeze Grip Type with Discharge hose & Special Nozzle
Fire Rating	≤ 3A	≤ 4A, 144B	≤ 2 A, 55B, 15 F, C

Also Available in Stainless Steel Body

Application :- LG-109/209 / LG-119/219

- Class A Fire** : Wood, Textiles, Paper, Plastic, Cloths, Cotton, Jute etc.
Class B Fire : Petroleum, Oil, Diesel, Paint, Varnish, Solvent, Aviation Fuel, Flammable and Volatile Liquids etc..
Caution : Do not use on Electrical Fire.

Application :- LG-164 / LG-166 / LG-169

- CAN BE USED ON MULTIPLE CLASSES OF FIRE.
- CAN BE USED ON FIRES INVOLVING LIVE ENERGIZED EQUIPMENT.
- TESTED AT 35000 VOLTS.



LG-209/ LG-219
(3A/ 4A, 144B)

LG-119/ LG-109
(4A, 144B/ 3A)



LG-164 / LG-166 / LG-169



Technical Specification

MODEL	LG-142	LG-144	LG-146
Capacity (Kg)	2	4	6
Anti-Corrosive Inhibitor	Epoxy Polyester Powder Coating	Epoxy Polyester Powder Coating	Epoxy Polyester Powder Coating
Confirming IS Code	15683	15683	15683
Type of Extinguisher	Constant Pressure	Constant Pressure	Constant Pressure
Type of Extinguishing Media	HFC 236 fa	HFC 236 fa	HFC 236 fa
Expellant	Pressurized with N ₂ gas	Pressurized with N ₂ gas	Pressurized with N ₂ gas
Minimum Effective Discharge (%)	95	95	95
Lancing Distance (mtrs.)	More than 2 mtr.	More than 2 mtr.	More than 2 mtr.
Discharge Time (Sec.)	13 seconds (Minimum)	13 seconds (Minimum)	13 seconds (Minimum)
Hydraulic Test Pressure (kgf/cm ²)	35	35	35
Operating Position	Upright	Upright	Upright
Charged Pressure (kgf/cm ²)	18	18	18
Operating Temperature Range(°C)	(-30 to +)60	(-30 to +)60	(-30 to +)60
Operating Valve	Squeeze Grip Type with Nozzle	Squeeze Grip Type with Discharge hose and Nozzle	Squeeze Grip Type with Discharge hose and Nozzle
Fire Rating	≤ 1A, 21B, C	≤ 1A, 34B, C	≤ 2A, 55B, C

Clean Agent Portable Fire Extinguisher



LG-144
(1A, 34B, C)

LG-146
(2A, 55B, C)



LG-142
(1A, 21B, C)

Also Available in Stainless Steel Body

Kitchen Portable Fire Extinguisher



IS-15683

 CM/L-0008633079



LG-154 /
 LG-156 /
 LG-159



Scan QR Code to
 Watch Demo

Technical Specification

PORTABLE	
MODEL	LG-154 / LG-156 / LG-159
Capacity (Ltr.)	4 / 6 / 9
Body	Stainless Steel Body
Confirming IS Code	15683
Type of Extinguisher	Constant Pressure
Type of Extinguishing Media	Wet Chemical
Expellant	Pressurized with N ₂ gas
Min. Effective Discharge (%)	95
Lancing Distance (mtrs.)	More than 2 mtr.
Discharge Time (Sec.)	13 seconds (Minimum)
Hydraulic Test Pressure (kgf/cm ²)	35
Operating Position	Upright
Charged Pressure (kgf/cm ²)	15
Operating Temperature Range (°C)	(+)-5°C to (+)60°C
Operating Valve	Squeeze Grip Type with Discharge hose & Special Nozzle
Fire Rating	≤ 15 F / ≤ 25 F / ≤ 75 F

Note: Red Epoxy Powder Coated SS Body due to IS : 15683 Compliant.

LIFEGUARD[®]
 FIRE PROTECTION EQUIPMENTS & SYSTEMS

'D' Class Powder Portable Fire Extinguisher



LG-129D

Technical Specification

MODEL	LG-126D / LG-129D
Capacity	6 Kg. / 9 Kg.
Working Temperature	+5°C to +55°C
Cylinder Testing Pressure	35 bar
Service Pressure	12 bar
Filling Tolerance	0,(-)5% by volume
Discharge Time (Sec.)	13 seconds (Minimum)
Charge	Special D Class Powder
Propellant	Nitrogen

Specially Designed Applicator Nozzle to extinguish metal fire from safe distance.

D type fire extinguishers contain blended sodium chloride, potassium chloride & barium chloride based dry powder, heat from fire causes it to cake and form a crust excluding air and dissipating heat from burning metal.

Self Triggered Stand Alone Type Fire Extinguisher



LG-1605/
 LG-1705

LG-1610/
 LG-1710

(Automatic Modular Type
 Fire Extinguisher)



Scan QR Code to
 Watch Demo

Technical Specification

Capacity	2kg	5kg	10kg	15kg
MODEL	LG-1602/LG-1702	LG-1605/LG-1705	LG-1610/LG-1710	LG-1615/LG-1715
Media	ABC Powder/Clean Agent	ABC Powder/Clean Agent	ABC Powder/Clean Agent	ABC Powder/Clean Agent
Area Coverage	2-3m ² Approx.	3-4m ² Approx.	5-7m ² Approx.	8-10m ² Approx.
Test Pressure	30 kgf/cm ²	30 kgf/cm ²	30 kgf/cm ²	30 kgf/cm ²
Anti Corrosive Treatment	Powder Coated	Powder Coated	Powder Coated	Powder Coated
Shell Diameter	175mm ±5%	240mm ±5%	300mm ±5%	405mm ±5%
Overall Height	185mm±25%	265mm±25%	350mm±25%	255mm±25%
Charged Weight	3.5 kg approx.	7.5 kg approx.	13.5 kg approx.	20.5 kg approx.
Bulb Temperature	56-107 (oC)	56-107 (oC)	56-107 (oC)	56-107 (oC)
Charged Pressure	15 kgf/cm ²	15 kgf/cm ²	15 kgf/cm ²	15 kgf/cm ²
Operational time in seconds	5-7	8-10	10-15	18-24
Type of Mounting	Ceiling	Ceiling	Ceiling	Ceiling

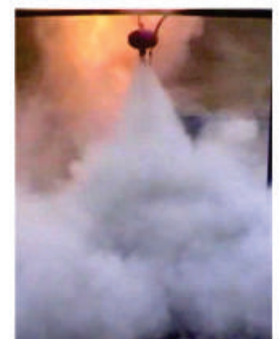

Carbon Di-Oxide Portable & Wheeled Fire Extinguisher



Technical Specification

MODEL	PORTABLE			TROLLEY MOUNTED			
	LG-132	LG-133	LG-134	LG-336	LG-339	LG-3322	LG-3345
Conforming IS Specn.	15683	15683	15683	16018	16018	16018	16018
Capacity (Kg)	2	3	4.5	6.5	9	22.5	45
Filling Ratio	0.667	0.667	0.667	0.667	0.667	0.667	0.667
Type of Extinguisher	CO ₂ Type	CO ₂ Type	CO ₂ Type	CO ₂ Type	CO ₂ Type	CO ₂ Type	CO ₂ Type
Type of Extinguishing Media	CO ₂ Gas	CO ₂ Gas	CO ₂ Gas	CO ₂ Gas	CO ₂ Gas	CO ₂ Gas	CO ₂ Gas
Expellant	Self	Self	Self	Self	Self	Self	Self
Min. Effective Discharge (%)	95	95	95	95	95	95	95
Discharge Time (Sec.)	More than 8	More than 8	More than 8	More than 20	More than 20	More than 20	More than 20
Lancing Distance (mtr.)	1	1	2	-	-	-	-
Operating Position	Upright	Upright	Upright	Upright	Upright	Upright	Upright
Operating Valve (IS 3224)	Wheel / Squeeze Grip Type	Wheel / Squeeze Grip Type	Wheel / Squeeze Grip Type	Wheel Type	Wheel Type	Wheel Type	Wheel Type
Operating Temperature Range (°C)	(-)30 to (+)60	(-)30 to (+)60	(-)30 to (+)60	(-)5 to (+)55	(-)5 to (+)55	(-)5 to (+)55	(-)5 to (+)55
Fire Rating	≤ 21B, C	≤ 34B, C	≤ 55B, C	≤ 55B	≤ 70B	≤ 89B	≤ 89B

Also Available in Light Weight Aluminium Body for Portable Extinguishers



Application :-

Class B Fire : Petroleum, Oil, Diesel, Paint, Varnish, Solvent, Aviation Fuel, Flammable and volatile liquids etc.
Class C Fire : Flammable Gases, Combustible Industrial Gases.
 Live electrical Equipments, Electrical Installation and Server Room etc.

MODEL	LG-2506	LG-2512	LG-2520	LG-2530
Capacity (in gms)	60	120	200	300
IS Specification No.	4947	4947	4947	4947
Complete Wt Empty (in gms) Approx.	530	810	980	1240
Complete Wt. Charged (in gms)	590	930	1180	1540
Working Pressure at 27±2°C (Kgf/cm ²)	140	140	140	140
Hydraulic Test Pressure (kgf/cm ²)	250	250	250	250
Dia of Pipe (in mm)	45	51	51	51
Overall Height (in mm)	151	181	245	350

CO₂ Gas Cartridge for Fire Extinguishers





Water Controlled Discharge



Foam Controlled Discharge



Powder Controlled Discharge

IS-16018

 CM/L-0008765605

LIFEGUARD[®]
 FIRE PROTECTION EQUIPMENTS & SYSTEMS

Wheeled Fire Extinguisher



LG-2145



LG-3145



LG-2225



LG-3250



LG-3275

Technical Specification

MODEL	WATER		FOAM		POWDER		
	LG-2045 LG-3045	LG-2060 LG-3060	LG-2145 LG-3145	LG-2160 LG-3160	LG-2225 / LG-3225	LG-3250	LG-3275
Conforming IS Specn.	16018	16018	16018	16018	16018	16018	16018
Capacity (Ltr.) & (Kg.)	45 (Ltr.)	60 (Ltr.)	45 (Ltr.)	60 (Ltr.)	25 (Kg.)	50 (Kg.)	75 (Kg.)
Type of Fire	A Class	A Class	A & B Class	A & B Class	BC/ABC	BC / ABC	BC / ABC
Type of Extinguisher	Water Type	Water Type	Mechanical Foam Type	Mechanical Foam Type	Dry Powder Type	Dry Powder Type	Dry Powder Type
Type of Extinguishing Media	Potable Water	Potable Water	Water & AFFF (2.7Ltrs. of 6% Concentrate)	Water & AFFF (3.6Ltrs. of 6% Concentrate)	Dry Chemical Powder	Dry Chemical Powder	Dry Chemical Powder
Expellant	Internal CO ₂ Gas Cartridge 300gm (IS 4947) / External CO ₂ Gas Cartridge 2 Kg	Internal CO ₂ Gas Cartridge 300gm (IS 4947) / External CO ₂ Gas Cartridge 2 Kg	Internal CO ₂ Gas Cartridge 300gm (IS 4947) / External CO ₂ Gas Cartridge 2 Kg	Internal CO ₂ Gas Cartridge 300gm (IS 4947) / External CO ₂ Gas Cartridge 2 Kg	Internal CO ₂ Gas Cartridge 300gm (IS 4947) / External CO ₂ Gas Cartridge 2 Kg	External CO ₂ Gas Cartridge 2 Kg	External CO ₂ Gas Cartridge 2 Kg
Min. Effective Discharge (%)	90	90	90	90	85	85	85
Lancing Distance (mtrs.)	6	6	6	6	6	6	6
Discharge Time (Sec.)	30 seconds (Minimum)	30 seconds (Minimum)	30 seconds (Minimum)	30 seconds (Minimum)	30 seconds (Minimum)	30 seconds (Minimum)	30 seconds (Minimum)
Hydraulic Test Pressure (kgf/cm ²)	35	35	35	35	35	35	35
Operating Position	Upright	Upright	Upright	Upright	Upright	Upright	Upright
Operating Temperature Range (°C)	+5 to +55	+5 to +55	+5 to +55	+5 TO +55	(-)5 to (+)55	(-)5 to (+)55	(-)5 to (+)55
Fire Rating	≤ 20A	≤ 20A	≤ 20A, 233B	≤ 20A, 233B	≤ 20A, 233B	≤ 20A, 233B	≤ 20A, 233B

Also available in UL Listed AFFF Chemical & Required capacities may be customized

Water/Foam Wheeled Extinguishers also Available in 125 Litres & 135 Litres

Application :-

Class A Fire : Wood, Textiles, Paper, Plastic, Cloths, Cotton, Jute etc.

Class B Fire : Petroleum, Oil, Diesel, Paint, Varnish, Solvent, Aviation Fuel, Flammable and volatile liquids etc.

Class C Fire : Flammable Gases, Combustible Industrial Gases, Live Electrical Equipments, Electrical Installation, Power Grid etc..

Use AR-AFFF in case of Polar Solvents.

**Wheeled Water Mist System & CAFS
(Compressed Air Foam System)**

IS-16018



CM/L-0008765605



LG-3645



**Backpack Water Mist
System & CAFS
(Compressed Air Foam
System)**

EN3



LG-3609

Technical Specification

MODEL	LG-3645	LG-3609
Extinguishing Agent Tank		
Conforming Specn.	IS 16018	EN 3
Filling Capacity	45 Litres	9 Litres
Material	Stainless Steel / Mild Steel	Stainless Steel
Working Pressure		
Pressure	7.0-8.0 bar	7.5 bar
Propellant Gas Bottle		
Medium	Compressed Air	Compressed Air
Pressure Cylinder M.O.C.	Steel Cylinder	Carbon Composite/ Steel Cylinder
Filling Pressure	300 bar	300 bar
Volume (water capacity)	6 Litres	2 Litres
Technical Parameters		
Operating Time	30 seconds (Minimum)	30 seconds (Minimum)
Flow Rate	-	24 litres/min
Operating Temperature	+5°C to +55°C	+5°C; Tmax + 60°C
Carrying Device	Ergonomically Shaped	Ergonomically Shaped
Extinguishing Gun		
Changeover Time	Approx. 3 Sec (Jet to spray mode)	Approx. 3 Sec (Jet to spray mode)
Lancing Distance	≥ 15m jet mode	Approx. 13-16m jet mode Approx. 6-7m spray mode
Ratings (Extinguishing Performance)		
A Class Fire	≤ 6A	55 A (as per EN3)
B Class Fire	≤ 233 B	233 B (as per EN3)
Dimensions		
Weight Empty (with the gas bottle & Valve)	45 kg Approx.	28 kg



Shut-off Nozzle
LG-421A

Thermoplastic Hose Pipe
LG-421B



LG-421

Technical Specifications

Type : Swinging 180° Wall Mounting

Size : Inlet 20mm/25mm

Conforming Specification : IS 884 : 2025

Performance Test

- Hydrostatic Test : Tested at 21 Kgf/cm²
- Range & Water Flow rate test at 7 Kgf/cm²
 - (A) Discharge : 27LPM / 44LPM
 - (B) Range (Jet Length) : 6mtr(min)

IS-884



CM/L-0003202027

Material of Construction :

- Hub Sides & Wall Bracket - M.S. / S.S. / Aluminum
- Swivel Joint - Brass
- Pipe with Fitting - Steel as per IS : 1239 Part I
- Shut off Nozzle - Brass / PVC
- Hose Reel Tubing - Thermoplastic Hose (IS:12585)
Rubber Hose (IS:444)

Compact Type Hose Reel



LG-421D

Specifications

Size : Inlet 20mm

Performance Test

- Hydrostatic Test : Tested at 21 Kgf/cm²
- Range & Water Flow rate test at 7 Kgf/cm²
 - (A) Discharge : 27LPM
 - (B) Range (Jet Length) : 6mtr(min)

Features

- Corrosion Free
- Powder Coated
- Light Weight
- IS:12585 Hose Reel Pipe with Bursting Pressure 14kg/cm²
- Hydraulically clamped CE Marked Nozzle

Landing Valve

IS-5290



CM/L-8530159522

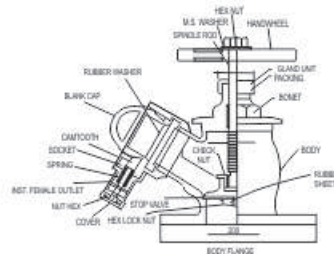

Gun Metal
LG-401



Stainless Steel
LG-402

Landing Valve (Double Headed)

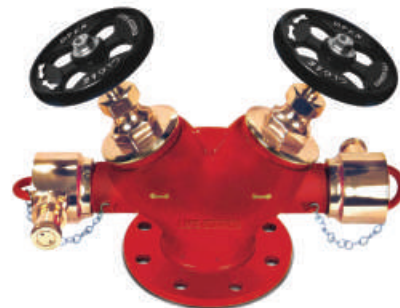

Gun Metal
LG-406

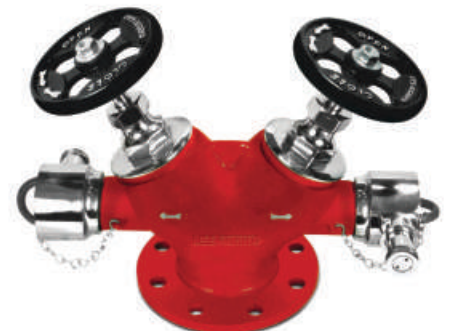

Stainless Steel
LG-407

Type of Material	Gun Metal	Stainless Steel
Model No.	LG-401/LG-406	LG-402//LG-407
Flow (LPM)	900/1800	900/1800
Water Tightness Pressure	14 Kgf/cm ²	14 Kgf/cm ²
Hydrostatic Pressure	21 Kgf/cm ²	21 Kgf/cm ²
Inlet Diameter	75mm / 100mm	75mm / 100mm
Outlet	63mm	63mm

Fire Hose Delivery Coupling



Gun Metal
LG-416



Stainless Steel
LG-417



Aluminum
LG-418

Branch Pipe & Nozzle



Gun Metal
LG-411



Stainless Steel
LG-412



Aluminum
LG-413

Type of Material	Gun Metal	Stainless Steel	Aluminum
Model No.	LG-411 / LG-416	LG-412 / LG-417	LG-413 / LG-418
Size	63mm	63mm	63mm
Nozzle Size	20mm	20mm	20mm
Hydrostatic Pressure	21 kgf/cm ²	21 kgf/cm ²	21 kgf/cm ²

Water / Foam Monitor



LG-526 0063
Water Monitor



LG-526 1063
Foam Monitor

Technical Specification

MODEL	LG-526 0063 / LG-526 1075
Material	Carbon Steel
Maximum Operating Pressure	12 bar (175 psi)
Flow Rate	1750 LPM @ 7 bar
Throw Range	55 Meters, Projection Angle : 30°
Inlet Flange	Flanged to IS:1538 100 NB (4") Raised Flange ANSI B 16.5 150 LBS
Monitor Outlet	2.5" Water way / Male BSP Thread Nozzle : Jet / Jet - Spray / Aqua Foam Nozzle with Pickup Tube
Barrel Size / Nozzle	63/32 / 75 / 38
Bore Dia NB in mm	
Hydrostatic Test Pressure	25 bar
Monitor Rotation	360° continuous
Monitor Elevation	(+) 90° above horizontal / (-) 45° below horizontal

Mobile Foam Unit



LG-527

It is a self contained Mobile Foam Unit for rapid deployment of foam extinguishing agent to fire in chemical spills where water (in most cases) proves ineffective in quenching hydro carbon liquid based fires in petroleum, chemical and other similar industries. This compact ready for action equipment consist of foam tank inductor, branch pipe and fire hoses ready to plugin to a suitable water supply.

TECHNICAL DETAILS

- Working pressure : 7kgf/cm² to 10kgf/cm²
- Max allowable back pressure : 65% of inlet pressure.
- Hydraulic test pressure : 25kgf/cm² for 5 minutes.
- Inductor : 3% or 6% fixed type
- Inlet / Outlet : Optional : Variable Type 63mm instantaneous Male GM/SS Coupling
- Dip Tube : SS 304
- Pickup Tube : PVC Braided Flexible Hose

Available in SS, MS & FRP

Fire Hose



LG-422B



CML-0009711381



LG-422H



LG-422A

Technical Specification

Type of Material	R.R.L. Hose Type 1	R.R.L. Hose Type 2	Synthetic Hose Type 3	C.P. Hose
MODEL No.	LG-422A	LG-422R	LG-422B	LG-422H
Inside (inches)	2.5	2.5	2.5	2.5
Dia (mm)	63	63	63	63
Bursting Pressure (kgf/cm ²)	21.4	21.4	25	21.4
Proof Pressure (kgf/cm ²)	35.7	35.7	42	35.7

(Also available UL Listed Fire Hose)

Automatic Sprinkler Heads (ISI Marked) & UL Listed



LG-503B
Pendent Type



LG-503F
Sidewall Type



LG-503D
Upright Type

IS-9972



CM/L-8700104711



Technical Data (Sprinkler Head)	
Approval :	Bureau of Indian Standards (IS 9972:2002)
Minimum Operating Pressure :	7 psi (0.5 bar)
Maximum Working Pressure :	175 psi (12 bar)
Factory tested hydrostatically :	30 bar
Thread size :	1/2" BSP
Nominal Bore or Orifice size :	15mm
Nominal K-Factor or Discharge coefficient :	80±4

Flexible Hose Pipe for Sprinklers



LG-540 Flexible Hose Pipe for Sprinklers



Available in following lengths :
700 mm, 1000 mm, 1200 mm, 1500 mm, 1800 mm
& two variants i.e. Non Braided and Wire Braided.

Fire Detection System



LG-545 IV
Fire Control Panel

LG-545 II
Fire Control Panel



LG-521MD
Multi Sensor Detector



LG-520A
MCP



LG-520B
Hooter

STANDARD FEATURES

- Complies to IS 2189:2008 and Tested by ERTL (N).
- 2 x 16 character backlit LCD display.
- 2 Wire Communication facility via RS 485 Port. (For Repeater Panel) (optional)
- Lamp test features.
- Complete with integral power supply and battery charger for SMF battery.
- NO/NC contacts for both fire and fault.
- Switches to enable on board operation.
- LCD and LED Indication for open, short circuit, Isolate, Fire in each zone.
- Maximum nos. of Detectors in each zone is 25

Control Panel also available in 6 Zone, 8 Zone, 12 Zone, 24 Zone, 36 Zone and can be customized.

Egress Edgelit Light

Features :

- Red LED indication on charging
- Constant Voltage Charging
- Fully Electronic, no moving part
- Reduced maintenance & installation cost
- Easy Read out
- As per IS 9583:1981

Technical Specification

Model	LG 642
Input Power	12V D.C.
Charging Current	60mA
M.O.C.	Aluminium / Acrylic
Color	WHITE / GREY
Dimension	300mm x 125mm / As per requirement
Battery	12 Volts



LG-642

Photoluminescent Signages

LG-528-01	EXIT	LADIES TOILET	LG-528-11	EXIT	FIRE EXTINGUISHER	LG-528-16
LG-528-02	FIRE EXIT	GENTS TOILET	LG-528-12	NO PARKING	INFORMATION	LG-528-17
LG-528-03	EXIT	FIRE EXIT	LG-528-13	NO SPITTING	NO ENTRY	LG-528-18
LG-528-04	EXIT	EXIT	LG-528-14	NO SMOKING	PARKING	LG-528-19
LG-528-05	WASH YOUR HANDS	FIRE ALARM	LG-528-15	PHONE	FIRST AID	LG-528-20

Customization can be done as per requirement



LG-528 Glow Signages

Emergency Light



LG-641



Side View

Features :

- Energy efficient & high intensity UL listed LEDs
- Prolonged service life
- Trickle charging
- Minimum maintenance
- Optimum utility
- Smooth operation
- Off white powder coated finishing
- Twin Approx 16 Watt UL Listed LEDs

Technical Specification

M.O.C.	Mild Steel
Dimensions (in Mm)	330 x 200 x 125
Gross Weight	5.00 Kg approx.
Input Voltage	220 Volt
Charging Time	10 hours approx.
Operating Time (on Battery)	3.5 hours approx.
Battery	7 Amph

In case of Emergency, the LED enlightens the pathway to be followed

Application :-

- | | | |
|-----------------------------|---------------------|---------------------|
| • Disaster management | • Hotels | • Corporate Offices |
| • Construction Sites | • Residential Areas | • Airports |
| • No power zone area | • Camps | • Railway Stations |
| • Hospitals / Nursing Homes | • Theaters | • Shopping Malls |



AGNI-RODHAK FLAMEPROOF COATING



Scan QR Code to
Watch Demo

LG-548



PROPERTIES OF AGNI-RODHAK



Flame
Retardant



Thermal
Control



Waterproofing



Durability

HOW TO APPLY

- BY SPRAY • WITH ROLLER • WITH BRUSH • BY DIPPING

APPLICATIONS OF AGNI-RODHAK

- LAUNCH VEHICLE • WATERPROOFING/THERMAL CONTROL OF CONCRETE
- HOUSEHOLD • RAILWAYS AND AUTOMOBILES
- PUF SEAT CUSHIONS IN PUBLIC TRANSPORTATION SYSTEMS
- AMMUNITION & EXPLOSIVES STORE HOUSES • OTHER USES

ACCREDITATION / CREDENTIALS

- United Fire Equipments Pvt. Ltd. is licensed to manufacture the product with authorisation from ISRO Dept. of Space, Govt. of India.
- **AGNI-RODHAK** has been tested and certified by ISRO & NABL accredited lab.

Bus Fire Detection & Suppression System



CREDENTIALS :
United Fire Equipments Pvt. Ltd. is licensed to manufacture the product with authorization from DRDO. The same is tested and certified by CFEES, DRDO.

BUS FIRE DETECTION & SUPPRESSION SYSTEM

(AIS 135 APPROVED)

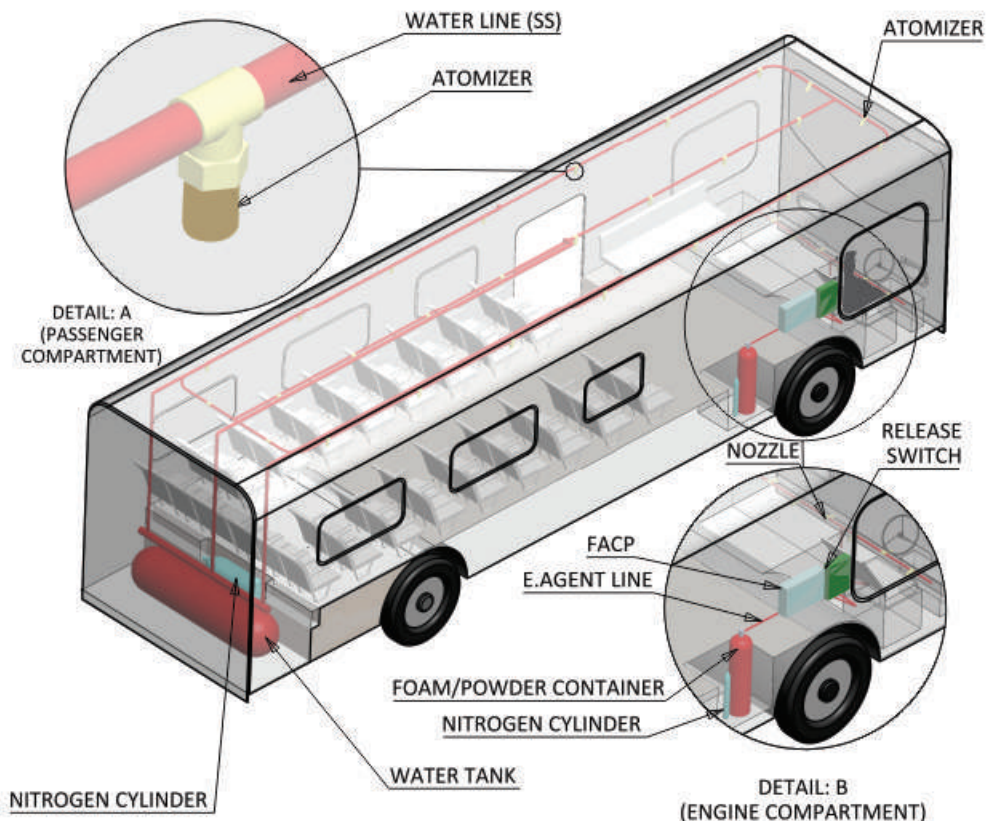

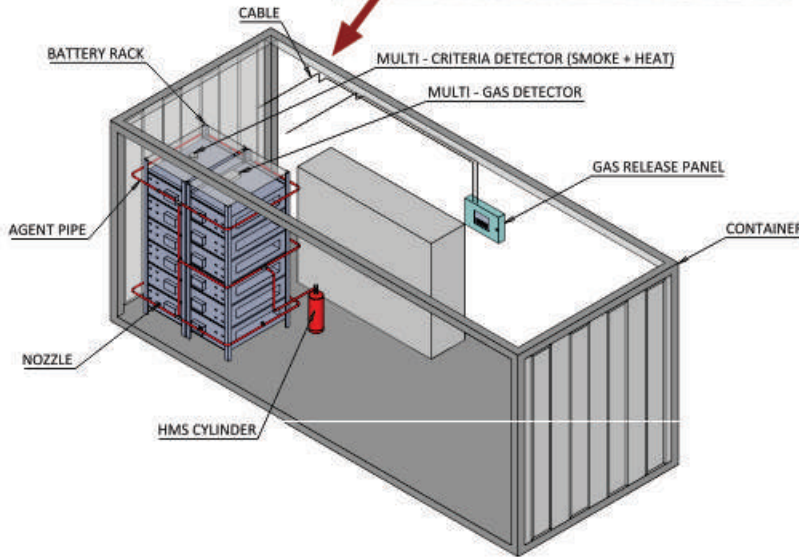

BESS LAYOUT WITH HMS BASED FIRE SUPPRESSION SYSTEM



Scan QR code to watch demonstration of LICH-Ex™ Fixed Suppression System



Eco Friendly



Non-Toxic



PHONES



LAPTOPS



CAMERAS



LIGHTS



E-CYCLE



E-BIKE



E-CAR



E-BUS

HMS™ (Hydrated Mica Suspension)

HMS™ Fire Extinguishing Agent: Your Comprehensive Solution for Lithium-ion Battery Fire Safety. Are you ready to confront the pressing challenge of lithium-ion battery fires head-on? Look no further than HMS™ Fire Extinguishing Agent—the pioneering solution engineered to tackle the distinct risks associated with lithium battery fires by Extinction Mechanism.

Revolutionizing Fire Safety

HMSTM isn't just another fire extinguishing option—it's a paradigm shift in fire safety technology especially for uncontrollable lithium-ion battery fires till date. Developed with state-of-the-art innovation, thorough realistic tests on Li-ion battery fires and a profound understanding of lithium-ion battery fire behaviour, HMSTM sets a new standard for performance, efficiency, and reliability.

Total Flooding System

(FK-5-1-12 / Inert Gas / Co₂ HFC 227 EA Suppression System)

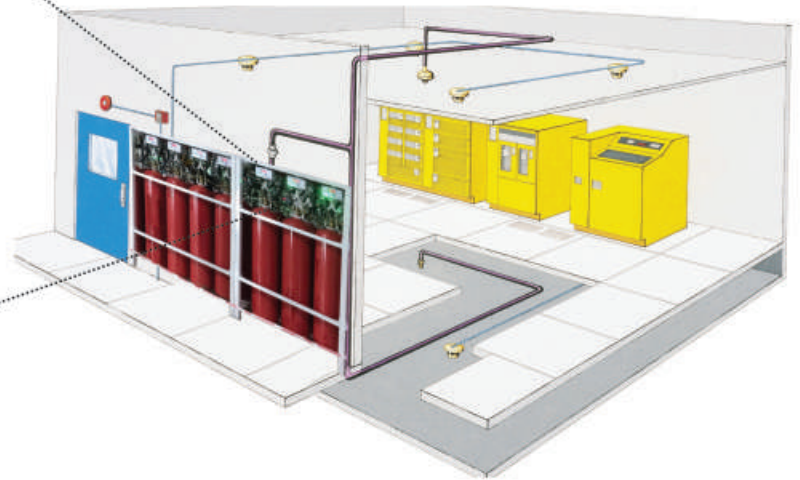
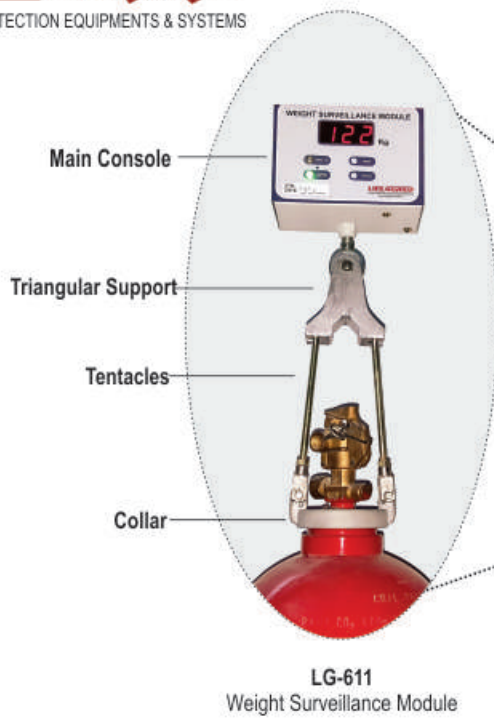

Tube Based Fire Suppression System



CNC Machines



Electrical Cabinets



Fume Cabinets

Kitchen Hood Fire Extinguishing System

S. No.	Qty	Description
1	1	ILP cylinder / valve assembly 9 Liter (not filled)
2	1	Cylinder bracket
3	1	Gasket
4	1	Tube fitting (nickel plated)
5	1	Steel hose
6	1	Tube fitting - straight union
7	4	Tube fitting - Elbow
8	1	Cross panel-fitting
9	6	Stainless steel tubing (1m)
10	4	Pipe bracket (Ø8mm)
11	2	Tube fitting - Tee
12	3	Tube fitting - straight G 1/4"
13	3	Nozzle
14	1	Cross panel-fitting
15	20	Screw clips for tube attachment
16	1	LIFEGUARD Tube red (10m)
17	1	Manual release device
18	1	Pressure switch
19	1	LIFEGUARD suppression agent

Optional		
20	1	Alarm Box

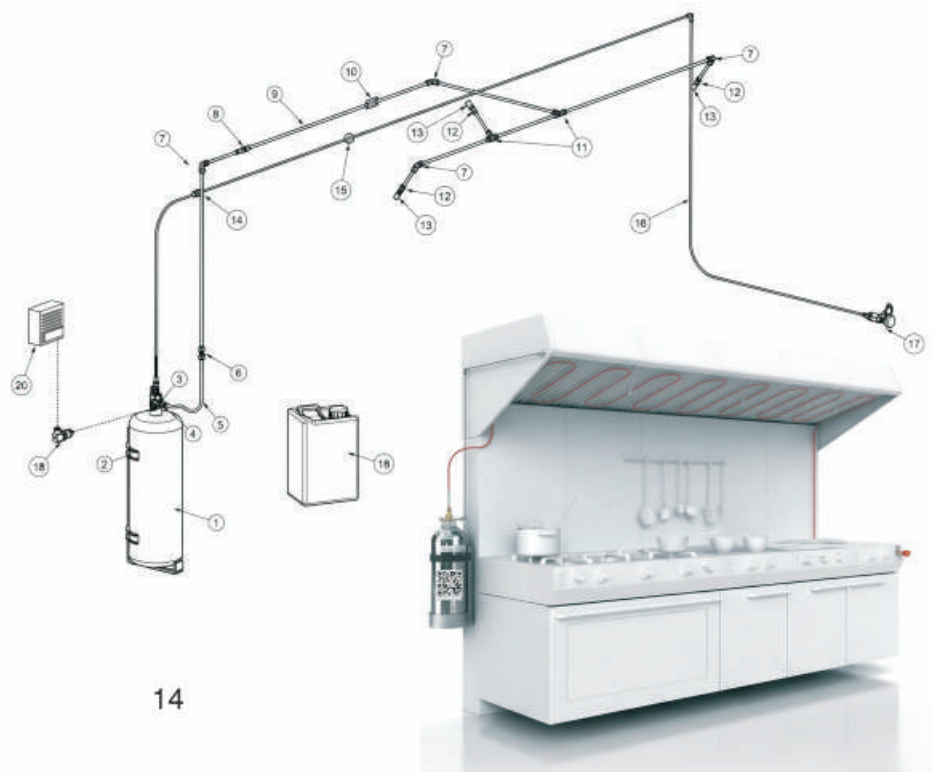

Accessories



LG-501
Hose Box



LG-534
Fire Extinguisher Stand



TESTED AT
20000
VOLTS

LG-538
Fire Man Axe



LG-542
Reflective Jacket



LG-525 P
Fire Bucket



LG-525 AC
Fire Bucket Stand with Canopy



LG-525 A
Fire Bucket Stand



4 Way
LG-423A



2 Way
LG-423B
Collecting Heads



LG-502
G.M. Draw out Connection



LG-516
Jumbo Water Curtain Nozzle



LG-524
Fire man Helmet

FIRE EXTINGUISHING CHEMICALS

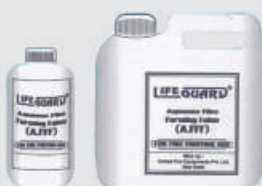

IS:4989
AFFF Refills
LG-551



IS:4308
Dry Chemical Powder (BC)
LG-552



IS:4308
Dry Chemical Powder (ABC)
LG-553



LG-504
FB-10X Foam Branch



LG-505
FB-5X Foam Branch



LG-522
Aqua Foam Nozzle



LG-550
Rosette Plate



LG-507
Suction Strainer



LG-508
Foot Valve Strainer



LG-509
Suction Coupling



LG-537
High/Medium Velocity Nozzle



LG-541
Water Curtain Nozzle

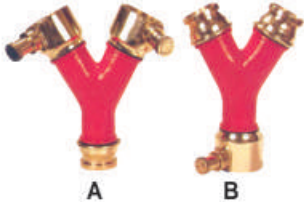

LG-506
Dividing Breaching



LG-510
Revolving Branch



LG-511
Fog Branch



LG-512
Triple Purpose Branch



LG-513
Double Male Coupling



LG-514
Double Female Coupling



LG-515
Gun Metal Adaptor



LG-517
Air Release Valve



LG-549
Fire Rescue Kit



LG-518
Electric Siren



LG-519
Manual Siren (Hand Operated)



LG-543
Gum Boots



LG-535
Fire Blanket



LG-522
Hand Control Fast
Action Pistol Grip Nozzle



LG-530
Fire Hook



LG-531
Fire Beater



LG-533
Rope Ladder

LIFEGUARD®

FIRE PROTECTION EQUIPMENTS & SYSTEMS

Esteemed Clients

LIFEGUARD®

FIRE PROTECTION EQUIPMENTS & SYSTEMS



SCAN QR CODE FOR
LIFEGUARD OFFICIAL WEBSITE.



UNITED FIRE EQUIPMENTS PVT. LTD.

AN ISO 9001:2015 CERTIFIED COMPANY

New Delhi - 110034

Navi Mumbai - 400701

www.lifeguardindia.in

IS-16018

CM/L-8765605



Registered with



GeM
Government e Marketplace

STQC
Certification



Authorised Dealer / Distributor

We reserve the right to alter specifications without prior notice.
Please refer the latest IS Codes for detailed information.

For Genuine **LIFEGUARD** Brand ISI Mark Fire Fighting Equipments Check Twice "3D" Hologram Sticker & Engraved

Version 3.26